

**Simulation Analysis of Power Factor Control Technique for CUK Converter**Apurva Patel<sup>1</sup>, Ashish Patel<sup>2</sup>*Lecturer, Department of Electrical, K. J. Institute of Engg. & Tech., Savli, India<sup>1</sup>**Assistant Professor, Department of Electrical, K. J. Institute of Engg. & Tech., Savli, India<sup>2</sup>*

---

**ABSTRACT:** *The importance of power-factor correction and the related line-harmonics reduction is increasing as the amount of line-fed electronic equipment grows and the requirements of regulatory agencies tighten. In this paper overview of hysteresis control technique for power-factor correction in DC-DC converters is compare with normal system. The simulation analysis for improve the power factor is shown in this paper.*

---

**KEYWORDS:** *DC-DC converters, PFC, THD, CCM, DCM*

**I. INTRODUCTION**

DC-DC converters are one of the important electronic circuits, which are widely used in power electronics. The main problem with operation of DC-DC converter is unregulated power supply, which leads to improper function of DC –DC converters. There are various analogue and digital control methods used for dc-dc converters and some have been adopted by industry including voltage- and current-mode control techniques. The DC-DC converter inputs are generally unregulated dc voltage input and the required outputs should be a constant or fixed voltage. Application of a voltage regulator is that it should maintains a constant or fixed output voltage irrespective of variation in load current or input voltage. Various kinds of voltage regulators with a variety of control schemes are used to enhance the efficiency of DC-DC converters. Today due to the advancement in power electronics and improved technology a more severe requirement for accurate and reliable regulation is desired. This has led to need for more advanced and reliable design of controller for dc-dc converters. There are various types of DC-DC converters required for particular purpose like Buck, Boost, Buck and Boost, Ćuk and Flyback. These all DC-DC converters have their specific configurations to complete their tasks. Varieties in DC-DC converter required different type of controlling techniques because single technique cannot be applied to all converters as the all have different specifications. Aim of this paper is to have an overview of all the control techniques used to ease the performance of various kinds of DC-DC converters. We will briefly discuss the basic concept, advantages and disadvantage of each control technique throughout this review.

**II. POWER FACTOR CONTROL TECHNIQUES**

Power Factor Correction is a technique that promotes efficient energy consumption from the power grid. Power Factor correction is employed inside common electrical and electronic equipment that are powered from the AC outlet. Power factor correction enables the equipment to maximize the *active* power draw and minimize the *reactive* power draw from the AC outlet. To operate the converter as a power factor corrector, consider continuous conduction mode: as the current stress and current ripple are minimum in this mode. A number of continuous inductor current mode control strategies such as average voltage control, hysteresis current control, and non-linear control techniques are reviewed in this paper.

**a.) Hysteresis Current Control**

Among the various control methods, hysteresis current control[7] is the extensively used technique owing to its noncomplex implementation, enhanced system stability, fast response, less distortion in input current waveform and regulating the output voltage.

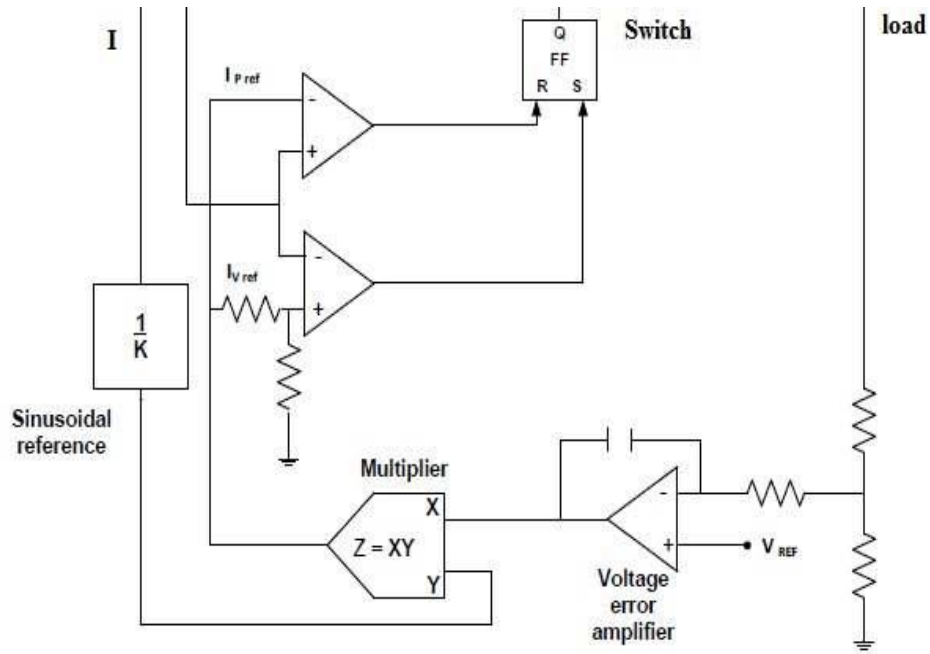

Fig.1. Control circuit for hysteresis control<sup>[7]</sup>

This technique is believed to exhibit greater stability. According to this control technique, when the inductance current is less than the lower current reference, power switch is turned ON and when the inductance current is more than the upper current reference, power switch is turned OFF. The boost converter is being operated at continuous current mode (CCM). For the hysteresis control, the inductance current is switching at a variable switching frequency. The switch must be turned ON while zero crossing of the line voltage for restraining very high switching frequency. In order to avoid too high switching frequency, the switch can be kept open near the zero crossing of the line voltage so introducing dead times in the line current.

Advantages:

- no need of compensation ramp;
- Low distorted input current waveforms.

Disadvantages:

- variable switching frequency;
- inductor current must be sensed;
- Control sensitive to commutation noises.

### III. SIMULATION RESULTS

The simulation is done to analyse the input voltage and current waveforms of the diode bridge rectifier and output waveforms across R and RL load. The diode bridge rectifier power factor is determined and the THD of the input current is also analysed.

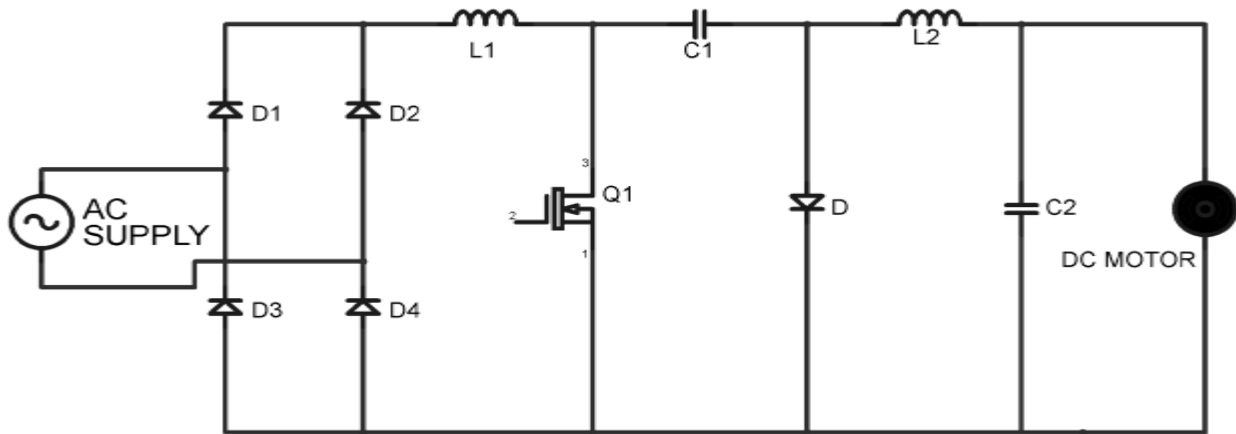

Fig.2. Circuit Diagram of bridge rectifier connected with ĆUK converter

Simulation Given below is a circuit diagram used for MATLAB simulation of ĆUK converter without control system and with control system. The purpose of this circuit is to compare output and input voltage and current waveform without control circuit and with control circuit. Also compare Power factor.

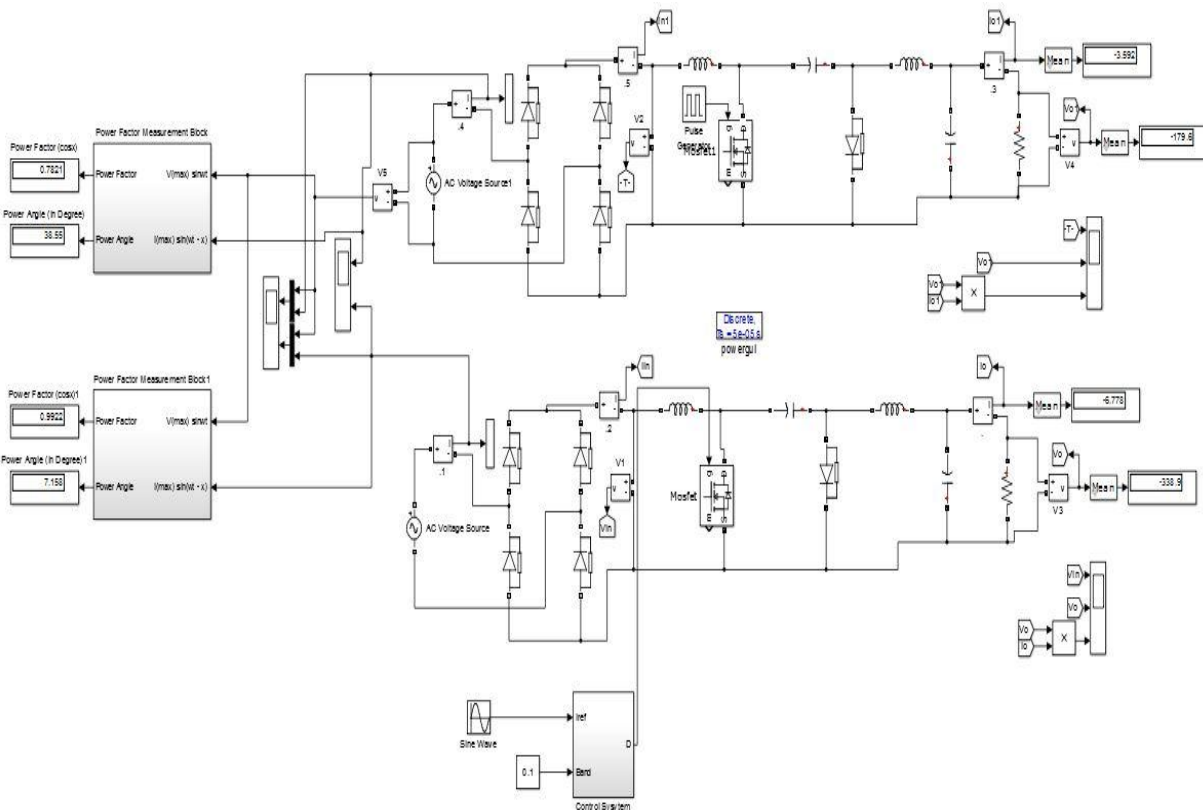

Fig.3. Simulation block diagram of ĆUK converter without control techniques and with Hysteresis control technique

Given below is a circuit diagram used for MATLAB simulation of Hysteresis control system. The purpose of this system circuit is to generate gate pulse for switch to on and off for improve the input current waveform

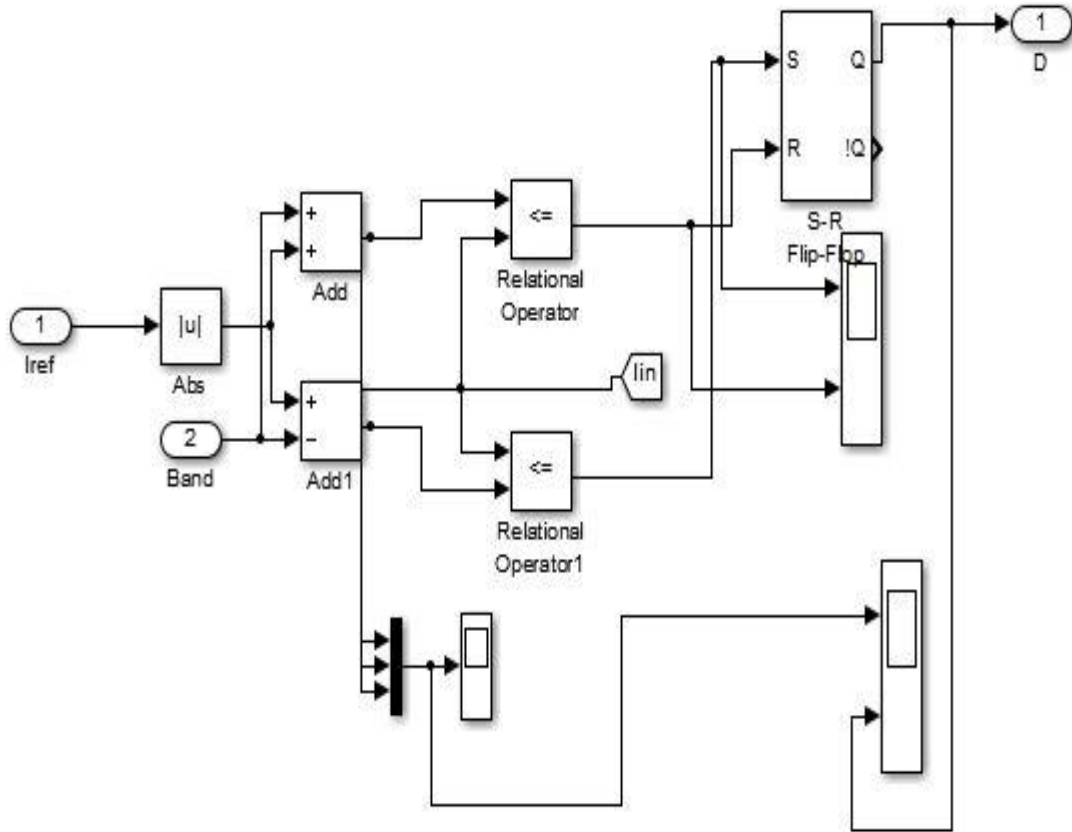

Fig.4. Simulation block diagram of Hysteresis control technique

#### IV. SIMULATION RESULTS

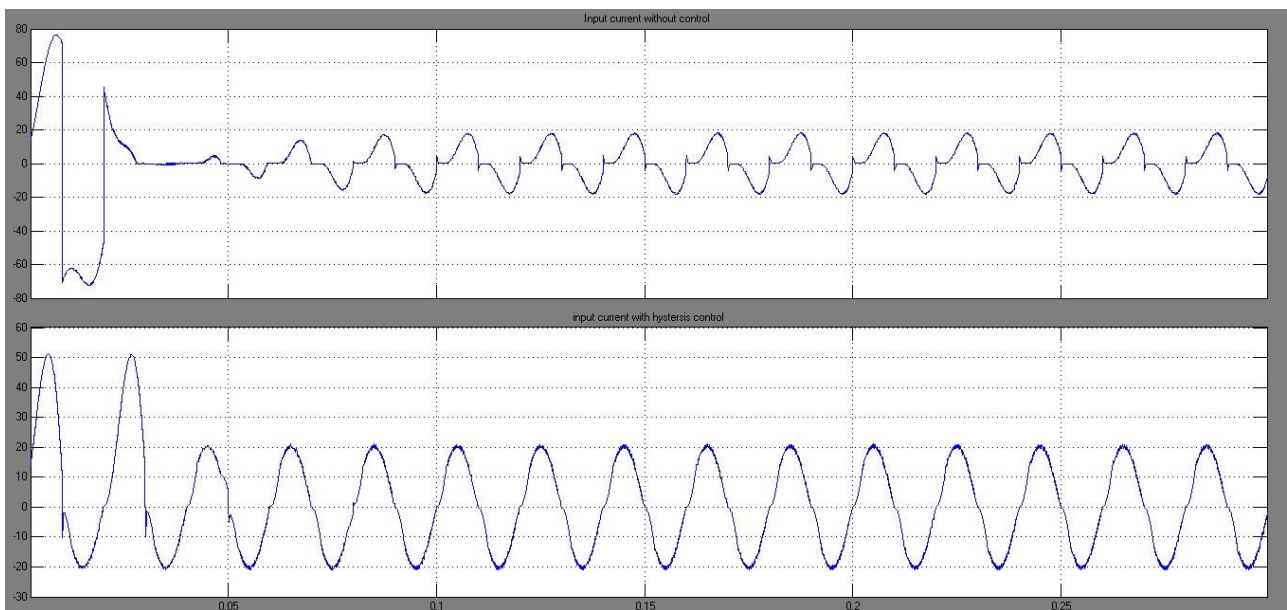

Fig.5. Simulation result of input current without control techniques and with Hysteresis control technique

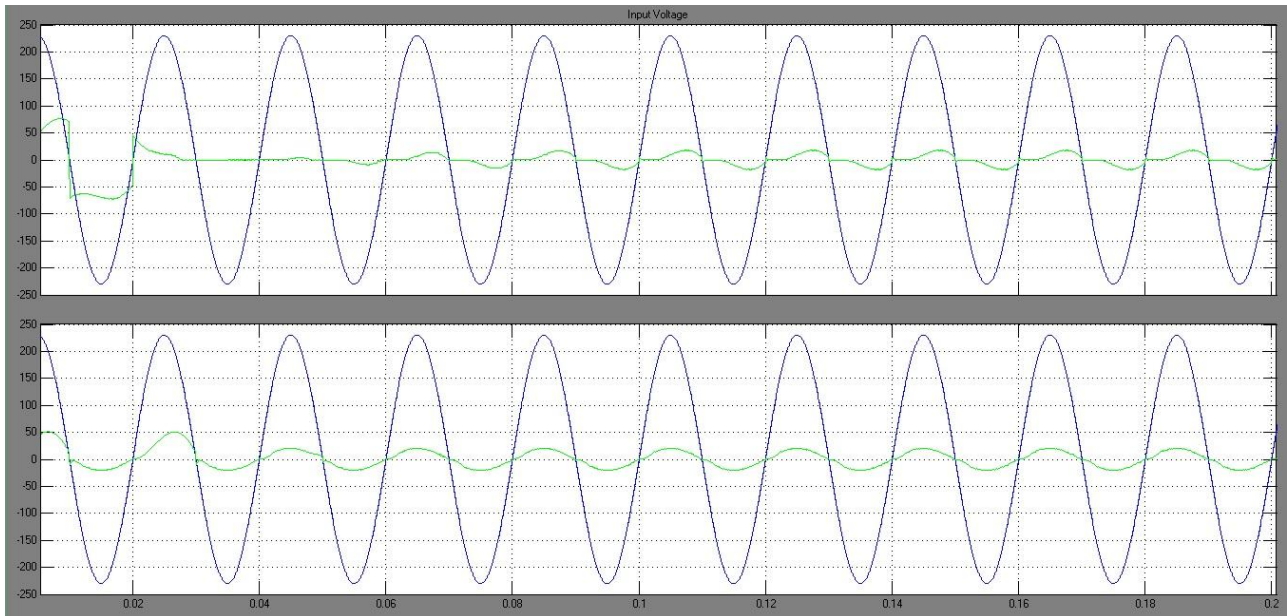

Fig.6. Simulation result of input voltage & current without control techniques and with Hysteresis control technique

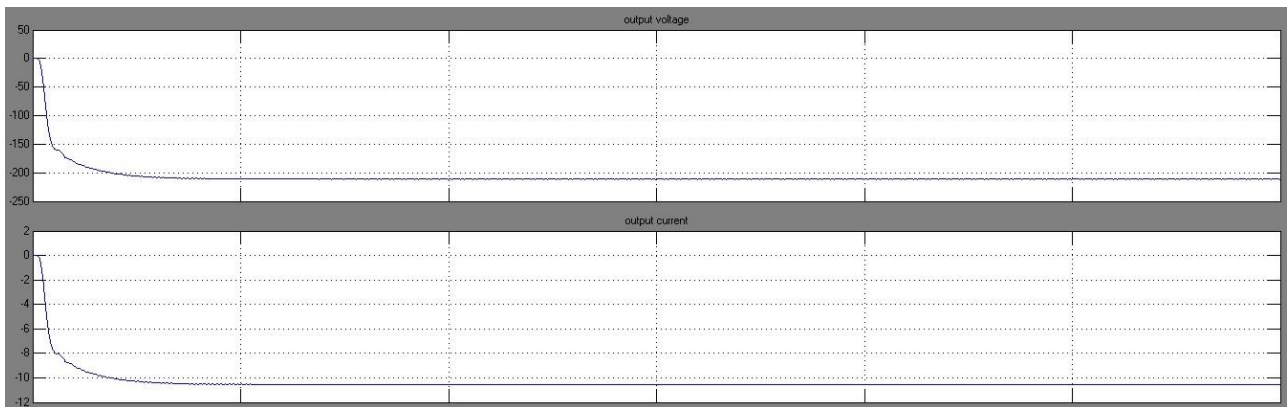

Fig.7. Simulation result of output voltage & current with Hysteresis control technique

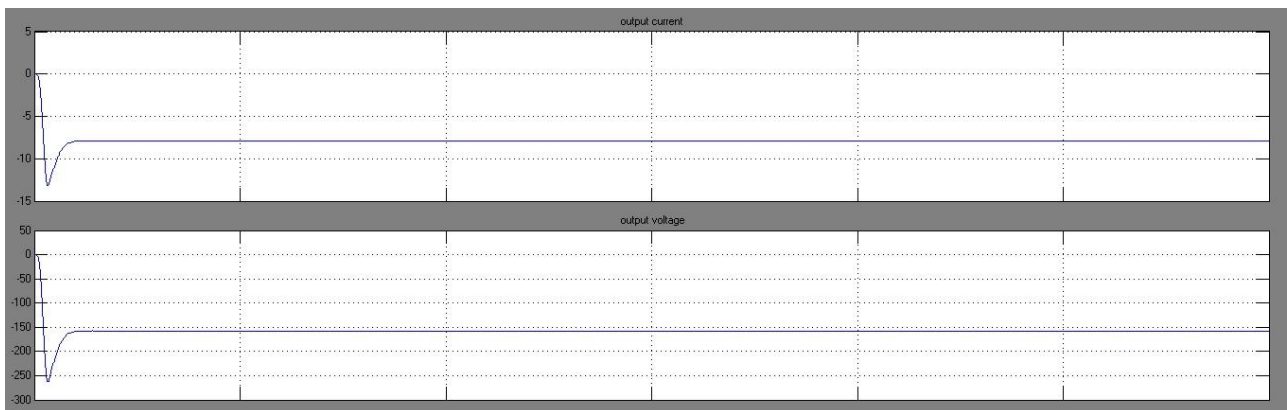

Fig.8. Simulation result of output current & voltage without Hysteresis control technique

The simulation results of cuk converter without control system and with hysteresis control system shown in figure 5, 6, 7 and 8. Figure 5 shown that input current without control system is not sin wave and with control system input current is almost sin wave after some time. Figure 6 shown that without control system, input voltage and current are not in phase but with control system, input voltage and current are in phase. Figure 7 and 8 shown that output voltage and current is

compare for with control and without control system and its near pure DC with control system. All the result shows that hysteresis control techniques power factor is 0.9947 compare with normal system. And it is improved.

## V. CONCLUSION

From the results, without any control system input current is not in phase with voltage and power factor is 0.73. with hysteresis control system current is in phase with the voltage and power is 0.9947. Power factor is improved using hysteresis control technique. So Efficiency of the system is increased and also quality of power is improved.

## REFERENCES

1. L. Rossetto, G. Spiazzi, P. Tenti, "control techniques for power factor correction converters.
2. Zhou, C., Ridley, R.B. and Lee, F.C. (1990) "Design and Analysis of a Hysteretic Boost Power Factor Correction Circuit", 21st Annual IEEE Power Electronics Specialists Conference, San Antonio, 11-14 Jun 1990, 800-807.
3. Maksimovic, D., Yungtaeklang and Erickson, R.W. (1995) "Nonlinear-Carrier Control for High Power Factor Boost Rectifiers", 10th Annual Applied Power Electronics Conference and Exposition, 2, 635-641.
4. Miwa, B.A., Otten, D. and Schlecht, M.E. (1992), "High Efficiency Power Factor Correction Using Interleaving Techniques", Proceedings of the 7th Annual Applied Power Electronics Conference and Exposition, Boston, 23-27 February 1992, 557-568.
5. M. Brkovic, S. ČUK, "Input Current Shaper using ČUK Converter", INTELEC Conf.Proc., pp. 532-539, 1992.
6. J. Klein, M. K. Nalbant, "Power Factor Correction - Incentives, Standards and Techniques", PCIM Conf. proc., 1990, pp. 26,28-31.
7. B. Andreyak, "Optimizing Performance in UC3854 Power Factor Correction Applications", Unitrode, Products & Applications Handbook, 1993/94.
8. Rashid M.H., Power Electronics: Circuits, Devices and Applications vol. (3rd Edition), Prentice Hall (2003).
9. Robert W. Erickson, Fundamentals of Power Electronics," 2nd Edition, Kluwer Academic Publishers.
10. Chen Z., Wu Q., Li M., Xu Y., Wang Q., "A three-port DC-DC converter with low frequency current ripple reduction technique.", APEC; 2015: 2069 - 2074.
11. C. A. Canesin, I. Barbi, "A Unity Power Factor Multiple Isolated Outputs Switching Mode Power Supply Using a Single Switch", APEC Conf. Proc., 1991, pp. 430-436.
12. R. B. Ridley "Average Small-Signal Analysis of the Boost Power Factor Correction Circuit", VPEC Seminar Proceedings, 1989, pp. 108-120.
13. B. Andreyak, "Optimizing Performance in UC3854 Power Factor Correction Applications", Unitrode, Products & Applications Handbook, 1993/94.



**Apurva Patel** received the Bachelors of Engineering in Electrical from Gujarat University, Gujarat, India in 2011, the Masters of Engineering in Electrical (Power Systems) from Gujarat Technological University, Gujarat, India in 2017. He is currently a Lecturer in K. J. Institute of Engineering and Technology, Savli affiliated with Gujarat Technological University. His current research interests include Power electronic circuits, Power Systems, Control systems, and Renewable energy.



**Ashish Patel** received the Diploma in electrical engineering from M.S. University of Vadodara, Gujarat, India in 2004, Bachelors of Engineering in Electrical from M.S. University of Vadodara, Gujarat, India in 2008 and Masters of Engineering in Electrical (Industrial Electronics) from M.S University of Vadodara, Gujarat, India in 2011. He is currently an Assistant Professor at K. J. Institute of Engineering and Technology, Savli affiliated with Gujarat Technological University. His current research interests include Industrial electronic, Microcontroller Circuits, Control systems, and Renewable energy.