



Advanced Life Detection System using Passive Infrared Sensor

Urvi Jadav¹, Meet Jani², Dipak Parmar³, Pushpa Bhatiya⁴

^{1, 2, 3} UG Students, Dept., of EIE,
Vadodara Institute Of Engineering, Vadodara, (India)

⁴, Assistant Professor, Dept., of EIE,
Vadodara Institute Of Engineering, Vadodara, (India)

Abstract - The project is based on life detection system. life detection system is uses passive infrared sensor which is used to detect living bodied during natural calamities like earth quack and fire. This system can detect peoples buried under debris and give signal to buzzer. The data fetching is done through the ATMEGA16 microcontroller. The whole system is working on principle of IR sensing unit. The detection circuit is mounted on a robotic car. In some risky and uneven areas where human can not work easily or risk free at that place this robot car can perform searching and detection better and rapidly. This is wireless robotic car and this operation is done using RF module. In RF module receiving unit is mounted on robotic car and transmitting unit is placed on remote control. Command for movement is given by switches which are decoded by ATMEGA16 and motors are operated.

KEYWORDS - Life Detection, Earthquake rubble, Passive infrared sensor, AETMEGA16 Controller, Robotic Car

I. INTRODUCTION

Some existing methods for detecting human victims buried under earthquake rubble are the use of sniffer dogs or some optical devices. Advanced life detection system is used to detect living humans in rescue operations and during hazardous events. This system mainly works on the principle of life detection using IR sensors. IR sensor is made up with Infrared LEDs and infrared receiver. The amount of light sensing is converted into voltage and the variation in voltage is fetch through op-amp and microcontroller. The blood in human body reflects the IR light so it can detect the buried person under debris.

On other side, At a time of any calamities we can search for a living things and we can set our priority of searching and rescuing at that part. We made one another modification of remote controlled car. As we know sometimes it is risky and difficult to perform rescue activities in hazard affected areas like collapsed building where there are chances of After Shocks and complete collapsing of building, at that time rescue team member may get injured. So, by using this remote controlled car with life detection circuit mounted on it, we can search more effectively and more safely, as it requires less space compared to man.

It is eco-friendly because of electrical power supply is used. After sensing life and processing by micro-controller the message will be displayed on LCD display. Our robot is wireless and transmitting and receiving of data is done using RF module. The life detection module is compact in size and easily mounted on any vehicle like drown, car, helicopter, boat etc... it can also carry in hand by human to detection of lives. We provided motors on all 4 wheels to provide more power to car. So that it can work under any challenging conditions & uneven surfaces. Radio frequency is the most suitable way to communicate and control the car from distance. As we know RF have working range of many kilometers with preciseness without any interruption. So we have used RF module as a transmitter and receiver. By using it we generate commands of particular frequency band with serial data for car movement and it is decoded by ATMEGA 16 Microcontroller and received by RF receiver module. Relays are provided for switching purpose. Main components of this project are PIR sensor, Heavy torque motors, Microcontroller, RF module, Static power relays, Batteries etc. This technology can be implemented on other vehicles with modifications. And also can be used for various purposes by changing its design, programming and range.

II. CIRCUIT DISCRPTIONOF THE SYSTEM

Input through detecting devices and sensors for detection and input through relays for motor driver operation Detecting device such As PIR sensor is used to sense and detect the passive infrared light rays emitted by living body. So basically it senses the passive infrared light from surrounding so it's name is PASSIVE INFRARED SENSOR. As soon as it senses the IR rays it gives signal to processing units it terms of change in voltage. For vehicle movement or motor driver operation relays are used such that every motor's forward-reverse is performed by 2 relays. So total 8 relays are used in H-bridge connection for switching 4 motors and movement of remote controlled car. Transmitter sends signals according to programming and relay will operate according to command and finally it results in motion of vehicle.

Processing through microcontroller ATMEGA 16 is a 32 pin IC including all basic facilities necessary for a reliable and satisfactory operation for all general purposes. It includes data pins, internal memory, ports for timer, interrupts , transmitter-receiver etc. In this project we are using 2 microcontrollers. 1 is used in detection circuit. This accepts the data from PIR sensor and process on it and gives output command to buzzer as well as LCD display. Programme is saved accordingly in microcontroller to convert readings taken by PIR into some figures and set value for command to indication systems(buzzer & LCD).

Another Microcontroller is used with RF (radio frequency) module to encode-decode the commands given by push buttons and operate motors/vehicle accordingly.

A. Block Diagram

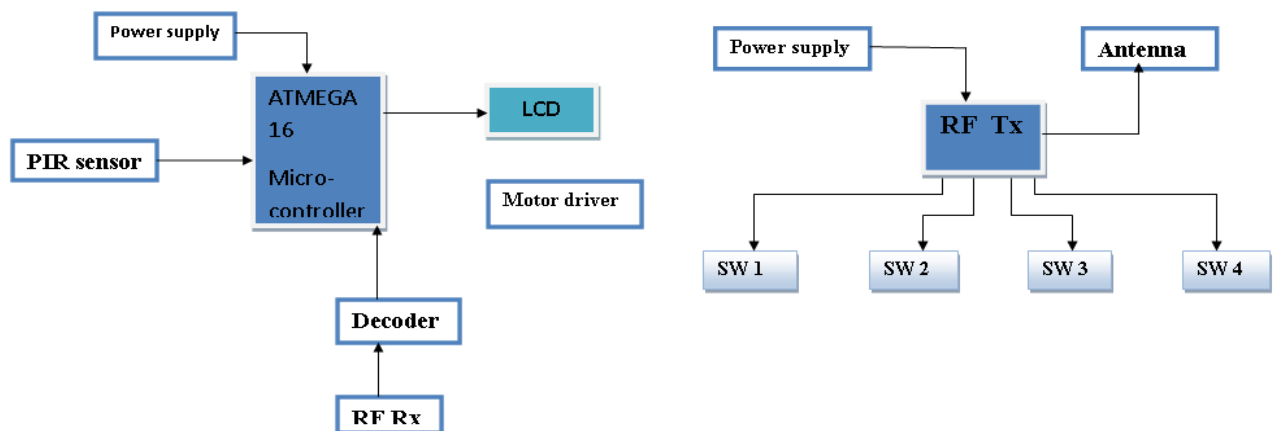

Figure 1. Block Diagram for Life Detection and Remote

B. Principle of working

This block diagram shows the basic working of our model. In detection circuit PIR sensor is used to detect the human presence and this data is then give to microcontroller. The microcontroller is fed with the commands and if human is detected then the signal is given to buzzer. PIR sensor is passive infrared sensor which detects the low bandwidth frequency and human body emits heat which is of low frequency. Microcontroller also drives the motors with the help of RF command. RF transmitter unit is mounted on motor and receiving unit is placed on detection robot car. As our robot car is wireless for communication purpose we are using radio frequency transmitter and receiver. The relay card is provided for smooth and error free operation of motors. 12V DC supply is given to the detection unit and 9V DC supply is given to the remote control.

C. Life Detection Circuit

We searched various technologies for life detection among them we choose to use PIR sensor. Passive infrared sensor is a sensor which is small in size accurate and also low cost. The range of the sensor is around 20 fit. The controlling is done

by using the microcontroller. In this circuit the three pins of PIR sensor Data, Input and ground is connected through ATMEGA16 pins and according to the program fed the detection single will generate.

D. Processing Through ATMEGA16 microcontroller

. we decided to use ATMEGA16 coz now a days is the most commonly used microcontroller and it have inbuilt ADC so data fetching is easy. After that we have to built our circuit and for that we use ISIS software which provide us a vast choice of designs. After making the circuit we built programming for life detection as well as motor driver control. ATMEGA16 is an 8-bit high performance microcontroller of Atmel's Mega AVR family with low power consumption. ATMEGA16 is based on enhanced RISC (Reduced Instruction Set Computing) architecture with 131 powerful instructions. Most of the instructions execute in one machine cycle. ATMEGA16 can work on a maximum frequency of 16MHz. ATMEGA16 has 16 KB programmable flash memory, static RAM of 1 KB and EEPROM of 512 Bytes.

E. Software used

The processing of inputs and output generation is in accordance with the programming of the microcontroller to take input and generate outputs. The microcontroller is programmed in Bascom.AVR specially designed for AETMEGA series.

HARDWERE PROTOTYPE

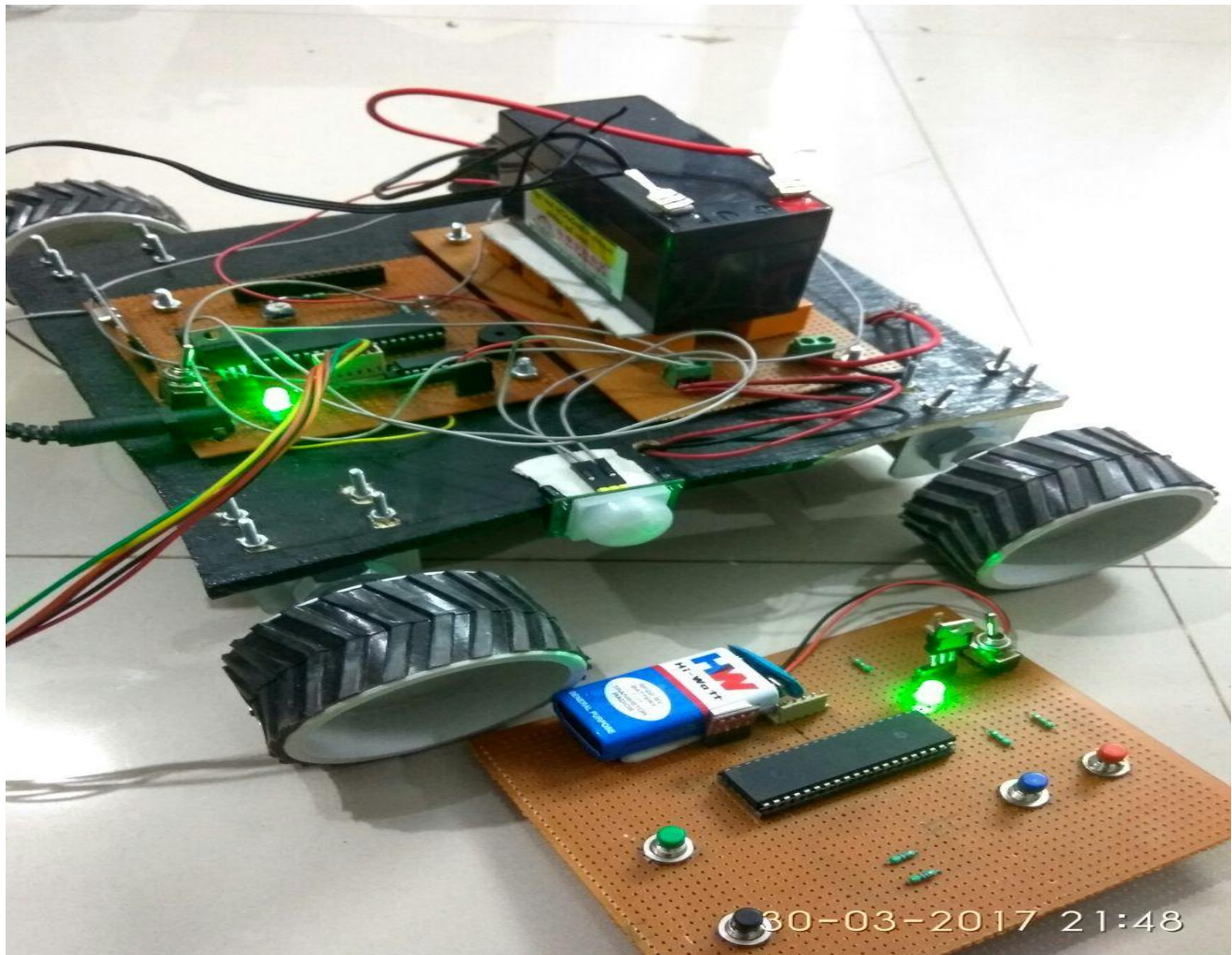

III. RESULTS

Output or indication part consist mainly 2 components:

- 1-Buzzer
- 2-LCD display

Buzzer is mounted on detection circuit and programming is done so , that whenever the condition for human presence is satisfied microcontroller sends signal to Buzzer as well as LED. So buzzer starts ringing loudly and LED also glows. At same time some values of voltage and other quantities are continuously displayed on LCD display. Whenever human is detected it's value reaches approximately Zero(0).

CONCLUSION

From survey we studied that sensor which detects the object is available but human detection system is not available. Our life detection system is good in every aspect. It can be reach every where and also reliable to use. We also notice that our sensor is far more sensitive to human and easily recognize the human. Our system use the LCD display and buzzer so its easy to recognize the place where human is detected. Modifications are easy according to requirement.

REFERENCES

1. Ashutosh Gupta, Betsy Thomas "A NEW REVOLUTIONARY INFRARED LIFE DETECTION SYSTEM USING ATMEGA168" International Journal of Embedded Systems and Applications (IJESA) Vol.2, No.3, September 2012.
2. Chen, K. M., Y. Huang, J. Zhang, and A. Norman, Microwave life-detection systems for searching human subjects under earthquake rubble and behind barrier," *IEEE Trans. Biomed. Eng.*, Vol. 27, 105{114,2000.
3. Colla, A.M. Sabatini, "A composite proximity sensor for target location and color estimation," IMEKO Sixth International Symposium on Measurement and Control in Robotics, Brussels, 1996, pp. 134–139.
4. L. Korba, S. Elgazzar, T. Welch, "Active infrared sensors for mobile robots," *IEEE Transactions on Instrumentation and Measuremen*, vol. 2(43), 1994, pp. 283–287.
5. A.M. Sabatini, V. Genovese, E. Guglielmelli, "A low-cost, composite sensor array combining ultrasonic and infrared proximity sensors, *IEEE/RSJ International Conference on Intelligent Robots and Systems (IROS)*, Pittsburgh, PA, vol. 3, 1995, pp. 120–126..
6. H.R. Everett, *Sensors for Mobile Robots*, AK Peters, Ltd., Wellesley,MA, 1995.
7. Benet, F. Blanes, J.E. Simo, P. Perez, "Using infrared sensors for distance measurement in mobile robots," *Journal of Robotics and Autonomous Systems*, vol. 10, 2002, pp. 255-266.