

**Optimization Technique To Estimate Maximum Power Point for Photovoltaic System**

Ankita Mardhekar<sup>1</sup>,

<sup>1</sup>PG Student, Electrical Engineering, Sarvajanik College of Engineering & Technology, Surat.

**Abstract**—The solar energy is the most important renewable energy source as it is clean, easily available energy source. To get maximum benefit of solar energy, the solar cells are developed and to operate these solar cells on their maximum efficiency, the solar parameters need to be determined and also to find the operating point of power which is called maximum power point. Here the five solar parameters are extracted using optimization technique called genetic algorithm and then maximum power point is obtained. The Photovoltaic system is simulated in MATLAB/Simulink based on the mathematical equation of the solar cell and the MATLAB coding is developed for extracting five parameters of solar cell and for maximum power point.

**Keywords**- Photovoltaic system (PV), Optimization Technique, Genetic Algorithm (GA)

**I. INTRODUCTION**

Now a days renewable energy sources are widely used, in that, the solar energy is the best one due to its characteristic like it is clean, secure, modular and requires very less maintenance. To get maximum benefits of solar energy, Photovoltaic cells are used. The photovoltaic cells are generally converted sun light into electricity based on the principle of photovoltaic effect. The Series and parallel combination of photovoltaic cells become Array and thus the whole PV system is created. Now the cost and performance of these PV systems are depend upon the electrical properties (parameters) of the modules. So the PV system designing and PV system investment decisions are very important task. For these different methods are used to extract solar parameters and here few of them related to optimization methods like Genetic Algorithm, Particle Swarm Algorithm, Fireflies Algorithm, Artificial Bee Colony Algorithm etc. are used. Also these optimization algorithms are used to estimate the maximum power point of PV array.

The main solar cell parameters are: the light generated current i.e. photocurrent ( $I_{ph}$ ), the diode ideality factor ( $n$ ), the shunt resistance ( $R_{sh}$ ), the series resistance ( $R_s$ ) and the reverse saturation current ( $I_o$ ).

This paper is organized as follows: In section II, the mathematical modeling of a PV module is presented. In section III, the problem formulation is defined. In section IV, the optimization technique is discussed. In section V, the simulation results are discussed with maximum power point. In section VI, it concludes the entire paper.

**II. MATHEMATICAL MODEL OF PV**

Generally for solar cell, the electrical equivalent circuit is used are the two types: (i) the single diode model and (ii) the double diode model.

A. Single diode Model:

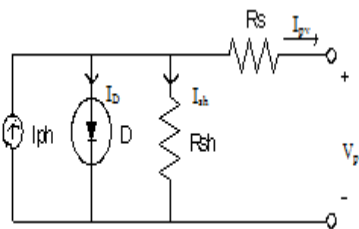

**Figure 1. Single diode model equivalent circuit diagram**

A photovoltaic cell is represented by an electrical equivalent one diode model, as shown in figure 1. This model consists of four components, (1) a photocurrent source  $I_{ph}$ ; (2) a diode parallel to the source; (3) a series resistor  $R_s$  and (4) a shunt resistor  $R_{sh}$  is illustrated. Here output of a current source is directly proportional to the light falling on the cell. The sun powered cell isn't a dynamic gadget; i.e. it neither produces a current nor is a voltage amid the dimness around then it functioning as a diode. Presently in the event that it is joined with the any outer source then it creates a current called  $I_D$  i.e. diode current or dark current, thus diode determines the I-V characteristics of the cell. The  $R_s$  gives a more accurate

shape between the maximum power point and the open circuit voltage. This likewise speaks to interior misfortunes because of the present stream. It portrays the increment of interface resistance with outer circuit. It is by and large kept little. The shunt resistance  $R_{sh}$  shapes the gem imperfections (non-homogeneous and material deformities) prompting misfortune streams going through the p-n intersection. For well-assembled sun powered cells, these deformities are minor so that  $R_{sh}$  is kept moderately high. It likewise compares to the spillage current to the ground and it is normally ignored.

The working mathematical statement portraying the I-V qualities of a PV cell got from figure is composed as the distinction between the photocurrent, the ordinary diode current and shunt current, which is given as:

$$I_{pv} = I_{ph} - I_o \left( e^{\frac{q(V_{pv} + I_{pv} R_s)}{nkT}} - 1 \right) - \left( V + \frac{I_{pv} R_s}{R_{sh}} \right) \quad (1)$$

Where,  $I_{ph}$  is the photocurrent,  $I_o$  is the reverse saturation current of the diode D,  $q$  is the electron charge ( $1.6 \times 10^{-19}$  C),  $n$  is the diode ideality factor,  $k$  is the Boltzmann constant ( $1.38 \times 10^{-23}$  Nm<sup>o</sup>K),  $T$  is the temperature (°K),  $R_s$  is the series resistance ( $\Omega$ ),  $R_{sh}$  is the shunt resistance ( $\Omega$ ),  $V_{pv}$  is the cell voltage,  $I_{pv}$  is the cell current. For the single diode model, five parameters to be extracted are parameters  $I_{ph}$ ,  $I_o$ ,  $R_s$ ,  $R_{sh}$  and  $n$ . An accurate knowledge of the parameters of solar cells is necessary for the design, control of solar cell and process optimization.

**B. Double diode Model:**

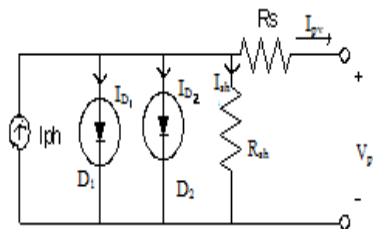

**Figure 2. Double diode model equivalent circuit**

Here a solar cell is represented by double diode model in which two diodes are connected in parallel. In which one diode acts as a rectifying diode. In practice the current source is also shunted by another diode that models the space charge recombination current and a shunt leakage resistor to account for the partial short circuit current path near the cell's edges due to the semiconductor impurities and non-idealities. Moreover, solar cell metal contacts and semiconductor material bulk resistance are represented by a resistor connected in series with the cell shunt elements. The equivalent circuit for this model is shown in Fig. 2.

**III. PROBLEM FORMULATION**

It is noted that current equation is nonlinear moving function. With a specific end goal to concentrate the parameters of distinctive sun based cell models from the I-V information utilizing the advancement systems, we initially need to characterize the target capacity to be advanced.

Here, the objective function is,

$$\chi = \sum_{m=1}^N (I_{measured} - I_{calculated}(V_i, \theta))^2 \quad (2)$$

where,  $\chi$  is the cost function,

$N$  is the no. of data points,

$I_{measured}$  is the measured value of current

$I_{calculated}(V_i, \theta)$  is the calculated value of current

Now the  $I_{calculated}(V_i, \theta)$  is given by following equation:

$$I_{calculated}(V_i, \theta) = I_{ph} - I_o (e^{q(V_i + I_i R_s)/nkT} - 1) - G_{sh}(V_i + R_s I_i) \quad (3)$$

Find Maximum Power Point using equation:

$dP/dV = 0$

(4)

#### IV. OPTIMIZATION TECHNIQUE

##### GENETIC ALGORITHM:

The hereditary calculation is effectively connected in the different fields and it is hunt calculation for the most part in light of Darwin's standard of "Characteristic Selection" and "the best one is survived". Here they consider numerous focuses in the inquiry space and they work with series of numbers speaking to the parameter set. There are such guidelines to guide their inquiry. The essential objective of the GA calculation is to locate the suitable arrangements that upgrade a given wellness or expense capacity beginning from an unevenly created populace of arrangements.

The Genetic Algorithm work with various populaces and every part in populace is called chromosome; is spoken to by binary chain; in which every binary is called gene; is conceivable arrangement after emphasis finished. Presently the individual from every era is assessed by particular criteria called fitness function; appropriately rank is given and from that the best one is chosen after the finish of Genetic Algorithms three fundamental procedures that are: selection, cross over and mutation.

The development of the Genetic Algorithm is mentioned below:

1. Initialize the quantity of generations (Gen: 0)
2. Generate an arbitrary starting populace.
3. Evaluate all of the individual chromosomes using fitness function.
4. Select the best ones from the assesment process of fitness function for production of new populace.
5. Apply genetic operators such as crossover and mutation to generate new one.
6. Evaluate these newly generated individuals.
7. Repeat step 4-5 until the end criteria is come to.

Genetic Algorithm landscapes are as follows:

Whereas recent optimization techniques suffer from localization based on the initial Point, Genetic Algorithm is not subject to the initial point.

Genetic A lgorithm scans for the global optimal solution in the entire range of feasible solutions and is insensitive to localized solutions.

#### V. SIMULATION RESULTS

##### 1 .MATLAB Simulink Model of Photovoltaic Module

*Table 1.Parameter specification of SOLKAR 36 W PV module*

Sr. No.	Parameter	Value
1.	Maximum Power ( $P_m$ )	37.08 W
2.	Voltage at Maximum Power ( $V_m$ )	16.56 V
3.	Current at Maximum Power ( $I_m$ )	2.25 A
4.	Open Circuit Voltage ( $V_{oc}$ )	21.24 V
5.	Short Circuit Current ( $I_{sc}$ )	2.55 A
6.	TotalNumber of cells in series ( $N_s$ )	36
7.	TotalNumber of cells in parallel ( $N_p$ )	1

**Simulink model of PV module:**

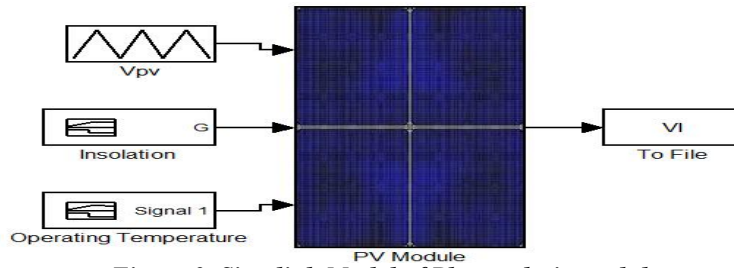

Figure 3. Simulink Model of Photovoltaic module

**Subsystem of PV Model**

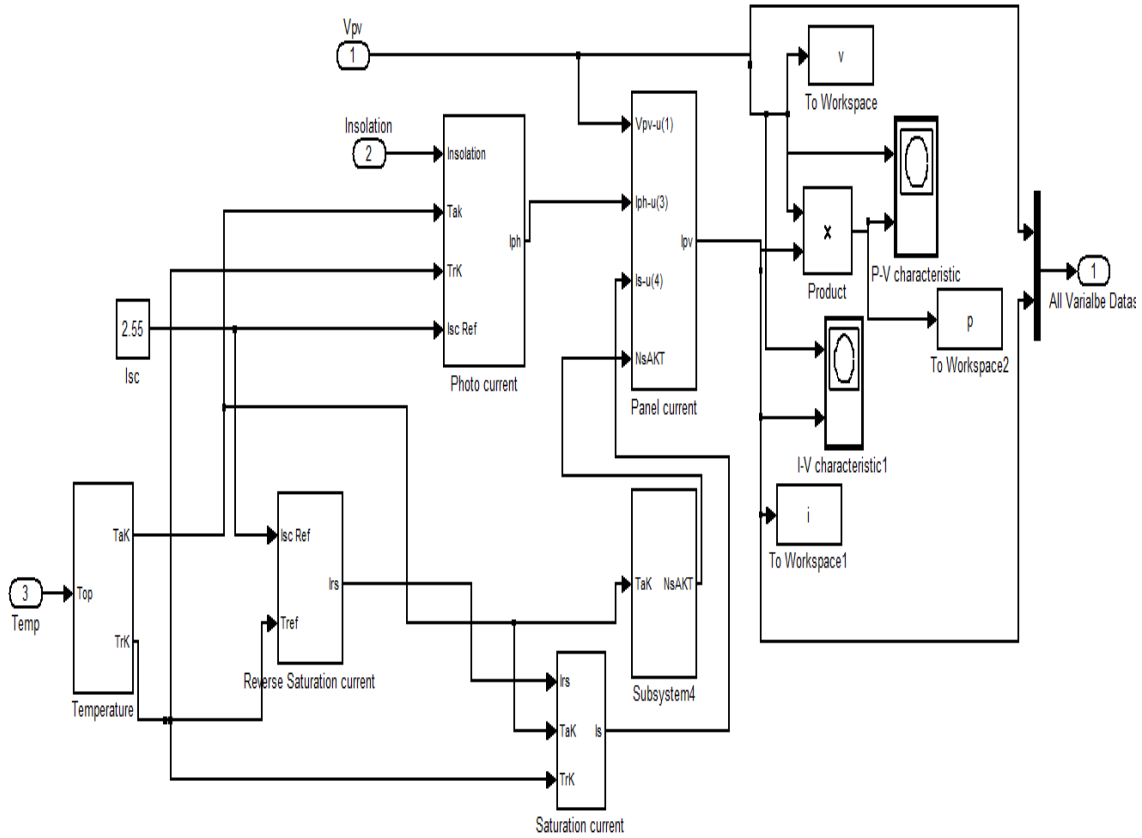

Figure 4. Subsystem of  $I_{pv}$

**IV Characteristics with different temperature IV characteristics with different insolation**

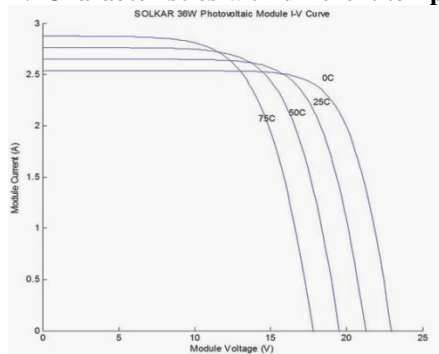

Figure 5. IV characteristics of solar system

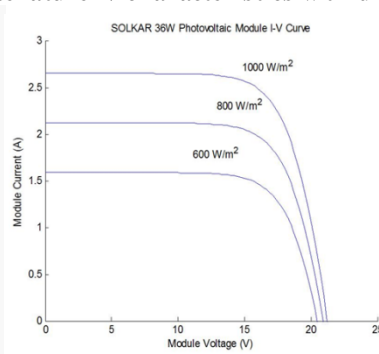

Figure 6. IV characteristics of solar system

**PV Characteristics with different temperature PV Characteristics with different insolation**

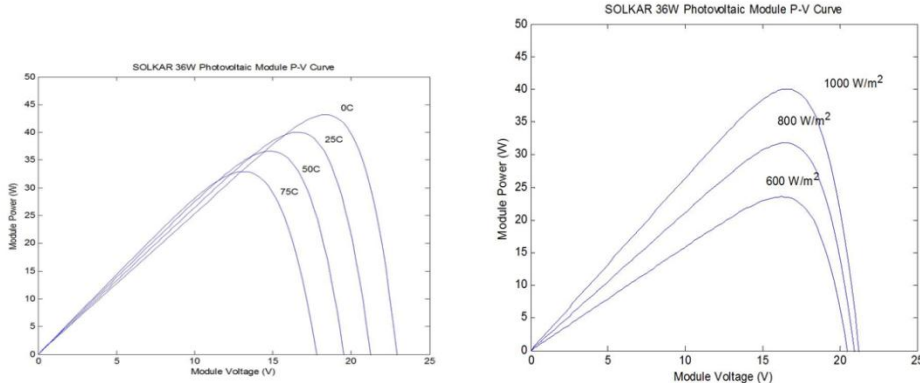

Figure 7. PV characteristics Figure 8. PV characteristics

#### IV - Curve fitting Using Genetic Algorithm

Here IV curve is fitted using characteristic equation:

$$I = I_{ph} - I_s \left( \exp \left( \frac{q \cdot (V + I \cdot R_s)}{n \cdot k \cdot T} \right) - 1 \right) - \frac{V + I \cdot R_s}{R_{sh}}$$

Variables are:  $I_{ph}, I_s, n, R_s, R_{sh}$

Here, following data are used:

Population size = 500

Length of variables = 5

Mutation rate = 0.08

Crossover probability = 0.35

No. of iterations = 700

IV curve is fitted using genetic algorithm for different insolation

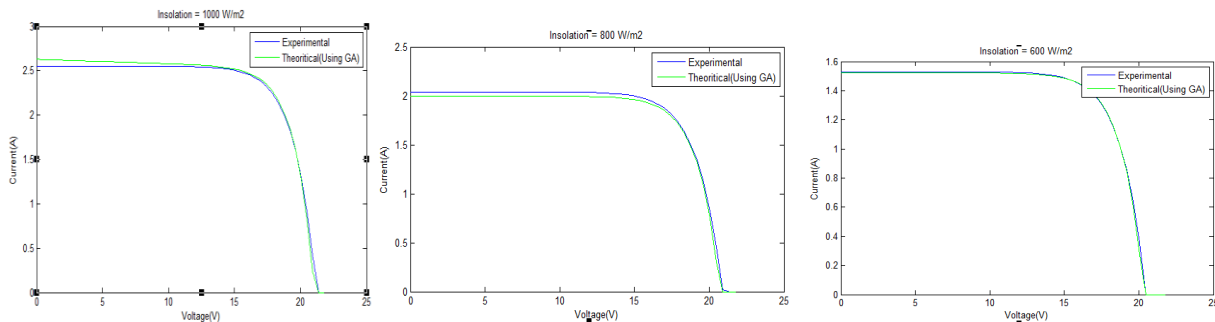

Figure 9. Insolation = 1000 W/m<sup>2</sup> Figure 10. Insolation = 800 W/m<sup>2</sup> Figure 11. Insolation = 600 W/m<sup>2</sup>

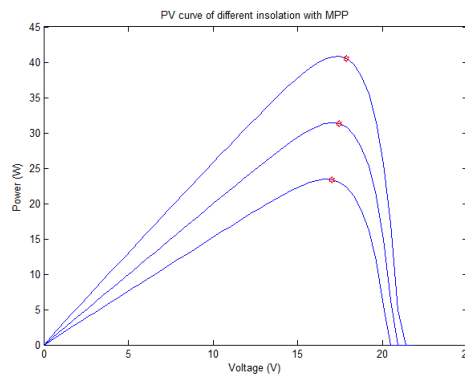

Figure 12. PV curve of different insolation with MPP

Table 2. Comparison between Actual value and by genetic algorithm value

Radiation W/m <sup>2</sup>	In Actual		By Genetic algorithm	
	V <sub>mpp</sub> (V)	P <sub>mpp</sub> (W)	V <sub>mpp</sub> (V)	P <sub>mpp</sub> (W)
1000	17.44	40.4742	17.876	40.5401
800	17.004	31.8706	17.440	31.3046
600	16.568	23.3669	17.004	23.3688

## VI CONCLUSION

Here PV model is developed using MATLAB Simulink blocks from mathematical equation and also prepared a MATLAB code of Genetic Algorithm to find voltage at maximum power (V<sub>MPP</sub>) for PV system. The continuous oscillation around the optimal operating point is an intrinsic problem of the active P&O tracking algorithm. These causes power loss and system instability [6]. The Incremental Conductance algorithm is developed to eliminate the oscillations around the MPP.

Another shortcoming for both algorithms is that the perturbation step of PV voltage set point is difficult to choose when dealing with the exchange between steady-state performance and fast dynamic response.

Therefore, it is desirable to determine the voltage of optimal operating point directly using Genetic algorithm, instead of tracking it simply through trial and error.

## REFERENCES

- [1] Mahdi M. El-Arini, Ahmed M. Othman and Ahmed Fathy, "A New Optimization Approach for Maximizing the Photovoltaic Panel Power Based on Genetic Algorithm and Lagrange Multiplier Algorithm", Journal of Emerging Trends in computing and information sciences, Vol.4, no.1, Jan 2013.
- [2] K. L. Lian, J. H. Jhang and I.S.Tian, "A maximum power point tracking based on perturb and observe combined with particle swarm optimization", IEEE Journal of Photovoltaics, vol.4, No.2, March 2014
- [3] BidyadharSubudhi, and RaseswariPradhan, "A Comparative Study on Maximum Power Point Tracking Techniques for Photovoltaic Power Systems", IEEE Transactions on sustainable energy, Vol.4, No.1, January 2013
- [4] S.Mallika, R.Saravanakumar, "Genetics Algorithm Based MPPT Controller for photovoltaic system", International Electrical Engineering Journal (IEEJ), Vol. 4 ,No. 4, pp. 1159-1164 ISSN 2078-2365, 2013
- [5] YacineLabbi, Djilani Ben Attous, " Maximum Photovoltaic Power Tracking under Different Conditions Using Genetic Algorithm and Particle Swarm Optimization", Journal of Electrical and Control Engineering, Dec.2012, Vol. 2 Iss.6 PG 7-13.
- [6] Slimane HADJI , KrimFateh , "Development of an algorithm of Maximum Power Point Tracking for Photovoltaic systems using Genetic Algorithms" , EFEEA'10 International Symposium on Environment Freidly Energies in Electrical Applications, November 2010
- [7] Solar Photovoltaics (Fundamentals, Technologies and Applications), Second Edition by Chetan Singh Solanki, PHI Learning Private Limited.
- [8] en.wikipedia.org/wiki/Maximum\_power\_point\_tracking
- [9] TrishanEsram and Patrick L. Chapman, "Comparison of Photovoltaic Array Maximum Power Point Tracking Techniques", IEEE transactions on energy conversion, vol. 22, no. 2, pg.439-450, June 2007.
- [10] Seok-II Go, Seon-JuAhn, Joon-Ho Choi, Won-Wook Jung, Sang-Yun Yun, "Simulation and Analysis of Existing MPPT Control Methods in a PV Generation System", Journal of International Council on Electrical Engineering Vol. 1, No. 4, pp. 446~451, 2011.