



International Journal of Advance Engineering and Research Development

Volume 2, Issue 7, July -2015

AUTOMATIC POULTRY FEEDER

Navaneeth B S^a and A K Murty^b

^aM.Tech in PDM, East Point College of Engineering & Technology Bangalore-560049

^bAssociate Professor, East Point College of Engineering & Technology, Bangalore - 560049

Abstract: *The growing need for poultry products by consumers has urged the necessity for small and medium scale poultry farmers to meet up the demand since they supply the bulk need of the market especially in the developing countries. There exist the need to produce birds that will meet the market standards within the shortest time without straining the farmer's time, resources and energy. In this project work an effort made to develop a labor/time saving automatically operated automatic feeder that will optimize feeding of birds. There exists many automated equipment's to feed birds in large scale poultries. But it is difficult or not possible to include large scale equipment's in small medium scale poultries. Normally small and medium scale poultries are run by farmers of rural areas. In small scale and medium scale poultries birds are fed with the feeder which requires frequent refilling of food. This consumes more labor and time increasing expenditure for farmers. With a view to facilitate easy and efficient feeding of food to chickens in small and medium scale poultries, it was proposed to design and fabricate an automatically operated poultry feeder.*

Keywords: *Automatic feeding equipment, small and medium scale poultry.*

I. INTRODUCTION

Over the last 20 years, due largely to genetic selection but partially to improvements in nutrition, there has been a substantial decrease in the time it takes to grow a broiler to market weight. Much of this improvement is attributed to increased food intake. The invention of improved mechanical feeding system led to a dramatic reduction in stress due to the elimination of manual feed sorting and relocation of birds by weight, more efficient feeding, less disturbance by staff, the elimination of meal replacement due to better weight control monitoring and increased productivity due to less handling. All of these factors contribute to the realization of the birds' genetic capabilities. There is also increased efficiency for the producer as no time is required to correct uneven bird weights and staff will have more time to devote to animal husbandry. The term "contract Poultry" refers to any genetic stock of poultry (unimproved or improved) raised intensively, semi-intensively or extensively in relatively small numbers. Most of the 826 million people still suffering from malnutrition and approximately 1,200 million people living on less than one US\$ per day are to be found in developing countries. Contract poultry represent an appropriate system for supplying the fast growing human population with high quality protein and providing additional income to resource-poor small farmers, especially women, although requiring low levels of inputs (i.e. housings, cages, feeds, breeds, vaccines, drugs, equipment and time/attention). Contract poultry contributes significantly to food security and poverty alleviation. Moreover, Family poultry constitute an important component of the agricultural and household economy in the developing world, a contribution that goes beyond direct food production as well as job and income generation for small farmers.

Poultry Feeders for small and medium scale farming

[1] Before the development of the automatic feeder technology, people were used to the conventional method of feeding chickens which is by filling containers with grains and foods manually. The main problem encountered by using this method is, the need to continuously provide the food, be alert and conscious of the food remaining in cages by the breeders. The sufficient amount of the food provided Also cannot be determined clearly There is much waste and is non-economical. Breeders also find that it is difficult to manage their business effectively because they need to be around the cages every now and then to monitor the poultry. [2] [3] There are various designs of feeding equipment which vary from country to country. Irrespective of the method of design, the guiding principles in feeder design is that it must be easy to small/medium scale poultry farms. Fill and clean; built to avoid waste; arranged such that fowls cannot roost on them; and constructed with durable materials in such a manner that so long as they contain feed at all, the fowl will be able to reach it with good feeding space. For about sixty-five years ago, almost all poultry feed was distributed by hand to birds mainly in square bottom troughs, wooden or metal feeders. Later mechanical and automatic feed systems were invented and they help to modify the feeding system, save labor and increase production. Now days, the automatic feeding system is available in the market. [4],[5],[6] This method is actually better than manual. But, there are also some problems and weaknesses that need to be overcome and solved, firstly, the automation, of the computerized method is suitable and caters more to the commercial purpose. Also there is the need for high investment for equipment and devices, and precise manual guide and knowledgeable as well as skilled people to operate the machines. More workspace is needed to put and assemble the automatic system. These are not favorable to the family poultry and small scale poultry operators. There is therefore the need for development of an efficient poultry feeder.

[2] Objectives of the study

Contract poultry and small/medium scale poultry farming are widely practiced by majority of Indian poultry farmers. The labor involvement and time demand for these poultry ventures make it arduous for most of the farmers. To ameliorate these problems in majority of the rural communities, improved automatic feeders are required in order to maximize time and reduce labor. This project attempts at solving the problems of high labor/time demand, feed wastage associated with small/medium scale poultry farms.

II. LITERATURE SURVEY

FEEDING EQUIPMENTS

Feeders are equipment's used in feeding poultry birds. The food is deposited in the feeder and the birds feed from it. The amount of feeders provided for a poultry farm should be according to amount of birds available. It is important that you always keep the feeders clean to ensure the health safety of the birds.

There are many feeders available for large scale poultries. Automatic feeding machines are available for both layer breeding and broiler breeding starting price of this feeding machine is around 300000 Rs. These systems are adoptable for large scale poultries but for small and medium poultries it's not worthy to adopt these automatic feeders to feed poultry birds. Small and medium scale poultries are normally found in rural areas run by farmers. For tem tat equipment cost itself is the total investment.

Layer feeds[7] are designed to provide optimum nutrition for birds laying eggs for consumption. This automatic feeding system works similar to electric overhead traveling (eot) crane. layer breeding of chickens is carried as shown by using this mechanism feeding becomes convenient.



Fig 1: automatic feeding equipment

Broiler poultries

Broilers are type of chickens reared for meat. To feed these chickens in large scale poultries big automated feeders are used as shown below.



Fig3: broiler feeding equipment

To feed chickens in large scale poultries feeders should be arranged as shown where all feeding plates are connected to a large continuous pipe which is connected to a hopper this closed pipe has openings at point where food should be fed to feeding plates. [8]Inside pipe a continuous spring is connected such a way that it acts as screw conveyor. At one end of pipe spring is connect to a motor. To implement this automated feeding in small scale poultries increases the investment. At present breeders in rural areas those are carrying contract poultries not using these equipments. Instead they use a small feeder which should be filled continuously by human effort

Hanging feeders

The Grower Feeders[9][10] eliminates feed wastage & that has three adjustment for controlling the feed level in feed pan. Maximum feed level should be for chicks and minimum for growers. Height of the feeder is adjustable and should be kept as high as possible. The Funnel (Extension) reduces feed wastage and increase effective feed conversion, help to pouring feed easily, reduce labor and save time. Grills are also available for growers.

Capacity of birds/Feeder	:	50
Feed Capacity	:	5 - 7 kg.
Cone (top) Dia	:	280 mm
Cone Height	:	228 mm
Pan (bottom) Dia	:	360 mm
Lip Space	:	55 mm
Grill Gap	:	55 mm

Table 1: capacity of birds and feeder[8]

Identifying problem

Now a day's, contract farming in poultry industry becoming popular among farmers by bringing profit additional to their agricultural activities. This needs additional labor, time extra care to look after chickens along with regular day works. Agriculture activities can sustain if a farmer doesn't attend agriculture activities for one week or more but in case of poultry farming it's needed to take care daily by feeding watering chickens. In order to avoid regular intervention of anybody to refill the feeder there is a scope to mechanize the feeding in poultry farming. Existing feeder can hold 5 to 6 kg of food. For fifty chickens it needs to fill the feeders two to three times daily. To avoid this feeding there is a scope to develop a master feeder which feeds the feeder as weight of small feeder becomes less. There are many mechanisms exists to feed in large scale industries but in case of small scale poultry farming in rural areas its needed to develop a simple mechanism.

Present work

To feed feeder from hopper it's required to regulate food flow to the feeder. In order to regulate food grains flow from hopper it needed to develop a mechanism. Food flow regulation should be achieved by sensing the weight of feeder. To feed chickens automatically feeders should be filled with food grains without the help of human effort. To achieve this one parameter should be considered that is weight. Weight of food inside the feeder is sensed, when feed level reaches maximum and minimum point. When food level becomes minimum feeder should be filled. The flow of food to feeder should be stopped when feeder attains maximum level.

. In this concept regulation of food flow from hopper will be achieved using rotary valve. Rotary valve is connected to shaft of dc motor. As motor rotates rotary valve also rotates during rotation of valve food flows from hopper to channel, where channel guides food to the feeder. Food flow will be stopped when motor stops.

Working principle

Working principle of this concept is to fill food grains to the feeder continuously, when food grains level in the feeder comes down to minimum and flow of food grains from hopper should be stopped when food grains level in feeder attains maximum. Since, feeder is placed on a weight sensing device load cell. This device sends signals to motor to start when weight of food grains in feeder reduces to minimum level, when food grains reaches maximum level in feeder another signal from load cell stops motor by stopping food flow. Slots of rotary valve are filled by vertical motion of food grains in feeder due to gravity. Valve gets its motion from motor as rotary valve rotates at top slots gets filled and gets emptied by conveying from hopper to channel.

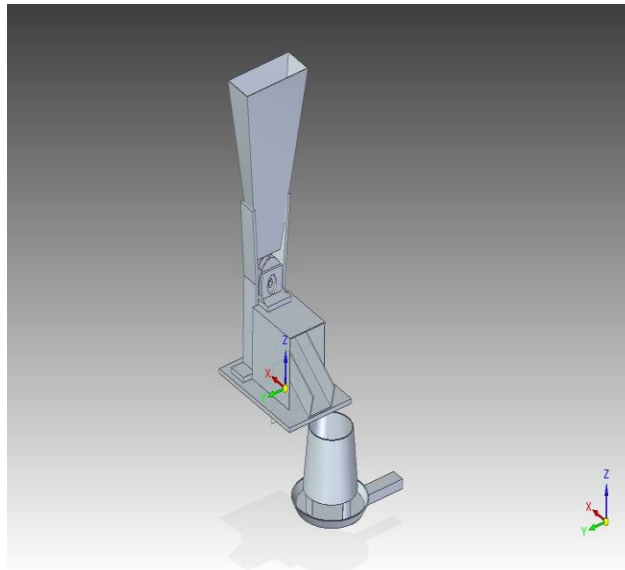

Fig 4: assembled figure of concept

Components used in the selected concept

1. Load cell
2. Feeder
3. Channel
4. Microcontroller circuit
5. Dc motor
6. Hopper
7. Supporting structures

Load cell

A load cell is a device that is used to convert a force into electrical signal. Strain gauge load cells are the most common types of load cells. There are other types of load cells such as hydraulic (or hydrostatic), Pneumatic Load Cells, Piezoelectric load cells, Capacitive load cells, Pezo resistive load cells...etc.

Load cells are used for quick and precise measurements. Compared with other sensors, load cells are relatively more affordable and have a longer life span.

Microcontroller

A microcontroller is a small computer on a single integrated circuits containing a processor core, memory, and programmable input/output peripherals. Program memory in the form of OTPROM is also often included on chip, as well as a typically small amount of RAM. Microcontrollers are designed for embedded applications, in contrast to the microprocessors used in personal computers or other general purpose applications.

Microcontrollers are used in automatically controlled products and devices, such as automobile engine control systems, implantable medical devices, remote controls, office machines, appliances, power tools, toys and other embedded systems. By reducing the size and cost compared to a design that uses a separate microprocessor, memory, and input/output devices, microcontrollers make it economical to digitally control even more devices and processes. Mixed signal microcontrollers are common, integrating analog components needed to control non-digital electronic systems.

Some microcontrollers may use four-bit words and operate at clock rate frequencies as low as 4 kHz, for low power consumption (single-digit mili watts or microwatts). They will generally have the ability to retain functionality while waiting for an event such as a button press or other interrupt; power consumption while sleeping (CPU clock and most peripherals off) may be just nano watts, making many of them well suited for long lasting battery applications. Other microcontrollers may serve performance-critical roles, where they may need to act more like a digital signal processor (DSP), with higher clock speeds and power consumption.

3 L293d motor driver

L293D are quadruple high-current half-H drivers. The L293 is designed to provide bidirectional drive currents of up to 1 A at voltages from 4.5 V to 36 V. The L293D is designed to provide bidirectional drive currents of up to 600-mA at voltages from 4.5 V to 36 V. Both devices are designed to drive inductive loads such as relays, solenoids, dc and bipolar stepping motors, as well as other high-current/high-voltage loads in positive-supply applications.

DC motors

The DC motor works on the principle of passing a current in a conductor inside a Magnetic field. A force is developed on the conductor. When a group of these conductors are fixed on a rotating armature, a resultant torque is produced from all the forces on the individual conductors.

Advantages

- Almost ideal Speed vs Torque motor characteristics.
- Possibility of obtaining variable and continuous dc voltage
- Simplicity for control (control paradigm)
- Large range of speed controllability

Rotary Valve

It is a compact mechanical device for continuously discharging bulk powders or granules under gravity flow. By definition it is the simplest of machines having only one moving part (ignoring the drive); a multi-vane rotor revolving in close contact in the housing and where the housing has an inlet at the top, and an outlet at the bottom.

Hopper

A **hopper** is a large, pyramidal shaped container used in industrial processes to hold particulate matter that has been collected from expelled air. Hoppers are usually installed in groups to allow for a greater collection quantity. They are employed in industrial processes that use air pollution control devices such as dust collectors, electrostatic precipitators, and bag houses/fabric filters. Most hoppers are made of steel.

III. RESULT

Small scale and medium scale farmers are differentiated based on number of birds they rear. Farmers rearing below ten thousand birds are considered as small scale, farmers with 10000-50000 birds are considered as medium scale. If we consider current criterion of small scale farmers they spend around 12000 rupees as labor charge per batch of 10000 birds. If a farmer rears ten batches per year he needs to spend around 120000 rupees on laboring wages. By automating of feeding we can reduce spending on labor by increasing profit.

Constructed model is efficiently shows working principle of the concept, the constructed model shows following performance,

Dc motor used has following capacity,

- 12 volts
- 800 mili amps
- 2 kg torque
- 60 rpm

Volume of hopper

$$V = \frac{1}{3} * h * ((a * b) + \sqrt{(a * b * c * d) + (c * d)})$$
$$= \frac{1}{3} * 320 * ((100 * 35) + \sqrt{(100 * 35 * 250 * 100) + (250 * 100)})$$
$$= 4037775.303 \text{ cubic millimeter or } 0.004037775 \text{ cubic meter.}$$

Density of food grains

Here we are taking maize density into consideration because maize is commonly used for feeding birds. Density of maize is 760 kilogram per cubic meter as given by agricultural department.

Total mass of food grains hopper can hold,

$$\text{density} = \frac{\text{mass}}{\text{volume}}$$

$$\text{Mass} = \text{density} * \text{volume}$$
$$= 760 * 0.004037775$$
$$= 3.06 \text{ kilo gram.}$$

From table 2.1 we know that average consumption of a bird per day

1 bird per day - 145 grams of food

For 20 birds - 2900 grams

$$\text{Number of birds} = \frac{\text{total food available}}{\text{amount of consumption per bird}}$$
$$= \frac{3000}{145}$$
$$= 20.68 \approx 21 \text{ birds}$$

- We can feed 20 birds continuously and efficiently for a whole day without any human interruption.
- In one minute rotary valve conveys 660 grams of feed from hopper to feeder.
- In ten minutes it is possible to completely fill one hanging feeder.

IV. CONCLUSION

Contract poultry and small/medium scale poultry farming are widely practiced by majority of Indian poultry farmers[11][12]. The labor involvement and time demand for these poultry ventures can be reduced for farmers. By implementing this concept of automatic feeding it is possible to maximize time and reduce labor. This project attempts at solving the problems of high labor/time demand, feed wastage for feeders associated with small/medium scale poultry

farm. Unsteady power supply problem in rural areas can be overcome by using solar panels since it requires very small amount of electricity.

From this project we came to conclusion that there is a potential scope to develop and introduce automatic technique to feed birds in small and medium scale poultries. By utilizing this opportunity many concepts are developed for automatic feeding from those concepts we narrowed down to the most simple and affordable concept.

This concept utilizes a rotary valve to convey food to feeder by rotary motion obtained by d c motor. This concept is successfully demonstrated which can feed 20 birds continuously and automatically for whole day once it filled.

REFERENCES

- [1] Journal of Emerging Trends in Engineering and Applied Sciences (JETEAS) 4(6): 837-846© Scholarlink Research Institute Journals, 2013 (ISSN: 2141-7016) jeteas.scholarlinkresearch.org
- [2] Automatic livestock feeders / www.poultrycoop.org
- [3] **APEDA**. 2006. Residue monitoring plan for 2006, for drugs and pesticides for exported egg products to the European Union. New Delhi, Agricultural and Processed Food Products Export Development Authority.
- [4] Bharadwaj, P.K. undated. Poultry market – opportunities for the farmers. Coimbatore, India, Suauna Poultry Farm Ltd.
- [5] Desai, A. 2004. An overview of the Indian poultry and future scenario. All India Poultry Year Book, Special Millennium Issue. Delhi.
- [6] **GOI**. 2006. Basic animal husbandry statistics. New Delhi, Ministry of Agriculture, Department of Animal Husbandry, Dairying and Fisheries.
- [7] Government of Kerala. Virtual university for agriculture trade. Department of Agriculture, Thiruvananthapuram, India.
- [8] Mohanty, S. & Rajendran, K. 2003. 2010 vision for Indian poultry. International Journal of Poultry Science, 2(2): 139–143
- [9] USDA, (2004), India's Poultry Sector, Development and Prospects, Agriculture and Trade Reports, Economics Research Service, WRS-04-03
- [10] Ramaswami Bharat, Bhirthal Pratap, Joshi P.K: February, 2005: Efficiency Distribution in Contract Farming: The case study of Indian Poultry Growers.